

The Power Wheelchair

What the SCI Consumer Needs to Know



Connect with Us:

Northern New Jersey Spinal Cord Injury System

1199 Pleasant Valley Way
West Orange, NJ 07052
<http://KesslerFoundation.org/NNJSCIS>

Kessler Foundation

SCIResearch@kesslerfoundation.org
www.Facebook.com/SCIRehabResearch
<http://KesslerFoundation.org>
Follow @KesslerFdn on Twitter

Kessler Institute for Rehabilitation

SCIRehab@kessler-rehab.com
www.Facebook.com/Kessler-Institute-for-Rehabilitation
www.kessler-rehab.com

University Hospital

www.uhnj.org

This publication was produced by the SCI Model Systems in collaboration with the University of Washington Model Systems Knowledge Translation Center with funding from the National Institute on Disability and Rehabilitation Research in the U.S. Department of Education, grant no. H133A060070.

Introduction

The wheelchair is a complex piece of equipment that has been extensively engineered and studied. Most individuals with SCI become wheelchair experts because doing so increases their chances of getting a wheelchair that truly meets their needs. However, power wheelchairs are technologically advanced and have many components, so it is critical to get help when purchasing a new chair (see the SCI Model Systems Consumer Information guide *Getting the Right Wheelchair: What the SCI Consumer Needs to Know*). While it is not possible to teach you all there is to know in a single handout, this factsheet includes some of the most important information.

Why Choose a Power Wheelchair?

A power wheelchair is appropriate if you are unable to propel a manual wheelchair or if you need to reduce the strain on your shoulders and arms so you can continue to perform transfers safely. The choice of power chair will depend on many factors, including the kind of surface conditions the chair will be driven over, the need to negotiate thresholds and curbs, and clearance widths in your usual environment.

Power Wheelchair Components

The Base

The power wheelchair base is the lower portion of a power wheelchair that houses the motors, batteries, drive wheels, casters and electronics to which a seating system is attached. It is classified according to drive wheel location relative to the system's center of gravity.

Rear-Wheel Drive

The drive wheels are behind the user's center of gravity, and the casters are in the front. It has predictable drive characteristics and stability but can be difficult to maneuver in tight places because of its larger turning radius.

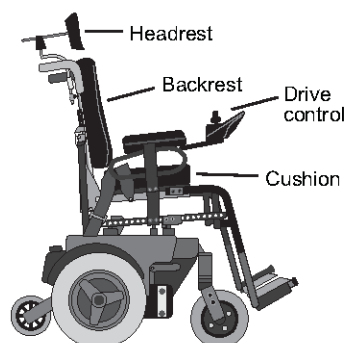

Figure 1. Rear-wheel drive power wheelchair

Front-Wheel Drive

The drive wheels are in front of the user's center of gravity, and the rear wheels are casters. This setup tends to be quite stable and provides a tight turning radius. However, it may have a tendency to fishtail and be difficult to drive in a straight line, especially when traveling fast on uneven surfaces.



Figure 2. Front-wheel drive power wheelchair with recline capability.

Midwheel Drive

The drive wheels are directly below the user's center of gravity. It has a smaller turning radius, making it more effective for indoor mobility, but not as good outdoors.

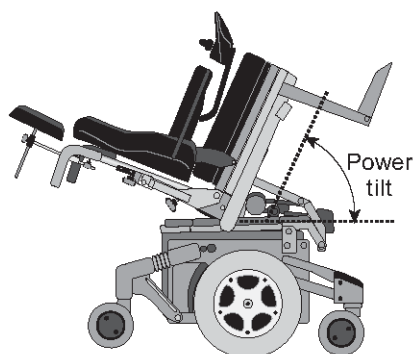

Figure 3. Midwheel drive power wheelchair with tilt-in-space capability.

Controls

The device used to control a power wheelchair is called an *access device* or *drive control*. It can also be used with environmental control systems and computer access. These controls are usually programmable and can be operated using various kinds of joysticks or switches (such as sip-and-puff).

Seating and Positioning

Seating and positioning are a critical part of your wheelchair and have an important role in your comfort, function, safety and health. Your seating system should be prescribed and designed specific to your medical, functional and personal preference needs, including protecting your skin from too much pressure.

Seating Systems

Seating systems fall into three general categories: off-the-shelf, modular and custom. In general, custom seating is only needed when musculoskeletal deformities are present such as scoliosis, or after a flap surgery for a pressure sore. The basic components of the seating system are the cushion and backrest.

Cushions and Backrests

Cushions and backrests are made out of a variety of materials, including contoured foam, air-filled bladders, combinations of air and foam, and gels. They vary in how well they address pressure distribution, postural stability, airflow, insulation or conduction of heat. Choice of style and material will depend on your individual needs and activities.

If all the needed features cannot be found in one cushion, trade-offs are necessary. Unlike with manual wheelchairs, the weight of the cushion and back support is generally not a consideration.

Research evidence suggests that a properly fitted pressure-reducing cushion, in contrast to a low-cost foam cushion, reduces the chances of getting a pressure sore.

Recline and Tilt-in-Space

Recline and tilt-in-space technologies relieve pressure, manage posture, provide comfort and help with personal care activities.

Recline (Figure 2), which changes the angle between the seat and backrest, helps to stretch hip flexors and makes attending to catheters, toileting and transfers more convenient for caregivers.

The addition of tilt-in-space (Figure 3), which tilts the seat and backrest together, keeps the hip and

knee angles constant when tilting back. This reduces the possibility of shear when in the recline position.

People who cannot independently shift weight or transfer should have a tilt-in-space and recline system on their wheelchair.

Seat Elevation & Standing Chairs

Power wheelchairs can also have elevating seats or mechanisms that stand the user upright while in the chair. Elevating seats can help with transfers, as it is easier to transfer downhill. In addition, elevating seats and standing chairs can make it easier and more functional to perform activities that are above shoulder height when sitting. Because performing activities above shoulder height puts you at risk of injuring your arms, recent guidelines recommend that all individuals with SCI who use power wheelchairs and have good arm function be provided with seat elevation.

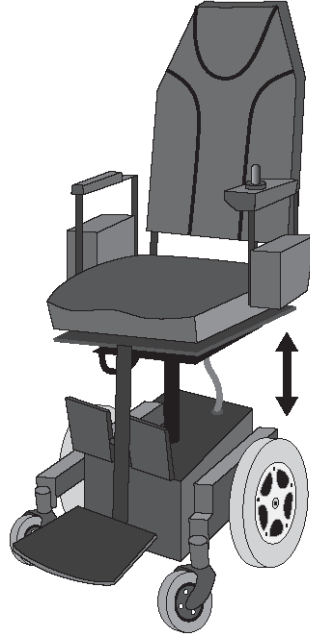

Figure 4. Power-elevating seat.

Power-Assisted Wheelchairs

Power-assisted wheelchairs are essentially manual wheelchairs with a motor that provides propulsion assistance when desired. This allows a user to propel the wheelchair more quickly and easily, and helps with obstacles such as steep ramps.

For individuals with shoulder pain or tetraplegia (quadriplegia), this can be a good compromise between a manual and power wheelchair.

Power-assisted wheelchairs are bulkier and less maneuverable than manual chairs, but they are less bulky, easier to transport and more maneuverable than power wheelchairs.

References

Boninger ML, Cooper RA, Fay B, Koontz A, *Musculoskeletal Pain and Overuse Injuries in Spinal Cord Medicine: Principles and Practices*, Demos Medical Publishing, NY, 2003.

Resources

- ABLEDATA is a non-commercial information center for assistive technology, including wheelchairs. Go to www.abledata.com (select *Products*, then *Wheeled Mobility*) or call 800-227-0216.
- Consortium for Spinal Cord Medicine, *Preservation of Upper Limb Function Following Spinal Cord Injury: What You Should Know* (Paralyzed Veterans of America, 2005).
- *Choosing A Wheelchair: A Guide for Optimal Independence* by Gary Karp (Cambridge, Mass: O'Reilly, 1998).

Also in the SCI Model Systems Consumer Information Series on Wheelchairs:

- *Getting the Right Wheelchair: What the SCI Consumer Needs to Know*
- *The Manual Wheelchair: What the SCI Consumer Needs to Know*

Source

Our health information content is based on research evidence whenever available and represents the consensus of expert opinion of the SCI Model System directors.

Authorship

The Power Wheelchair: What the SCI Consumer Needs to Know was developed by Michael Boninger, MD, in collaboration with the University of Washington Model Systems Knowledge Translation Center.

Disclaimer

This information is not meant to replace the advice from a medical professional. You should consult your health care provider regarding specific medical concerns or treatment.

